

star

SR-32J

CNC SWISS TYPE AUTOMATIC LATHE

New

A New High Speed Star is born, achieving 24m/min rapids and driven tool capability for the sub spindle



Power with maximum rigidity and high output drives are engaged for large diameter components

□ TOOL POST

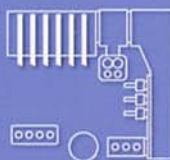

□ WORK SIZE (MAX.)



□ CONTROL SYSTEM





Power with maximum rigidity and high output drives are engaged for large diameter components.

The tool post configuration, slant mounting and dovetail guide face provides excellent cutting rigidity. Heavy cuts on large diameter material can be performed with excellent effect due to 16mm section cutting tools and high main drive motor output (main spindle 5.5/7.5 kw. sub spindle 2.2/3.7 kw)



Versatile machine providing comprehensive capability.

The comprehensive machining capability has been improved by adding drilling tools and end working driven tools* and mounting dynamic driven tool motors. The machine is equipped with sufficient functions to suit a 32mm compact machine including the facility to overlap the main and sub spindle.

*The machine can be mounted with up to 2 counter-face type drill sleeves (up to 4 can be mounted subject to the geometric conditions) and up to 9 cross front end and rear end driven tools



Competitively priced to pursue the cost reduction of turned parts.

Reasonable pricing is realized by appropriately selecting functions for complex machining. In addition, the running cost is minimized due to electric power saving in non-hydraulic system.



SR-32J has been accomplished at low cost and it has high rigidity, high output drive and complex machining capability.

Now, high performance machining of large diameter parts can be done at a reasonable cost.

TOOLING SYSTEM

Tool post & Tooling

Gang Tool Post

Tool holder	Turning tool	● 6 tools	
Sleeve holder	Front-end Working Stationary tool	● 4 tools	※1
	Rear-end Working Stationary tool	● 4 tools	※1
Power-driven tool	Cross Working Driven tool	● 4 tools(Max.)	※2 ※3
	Front-end Working Driven tool	● 3 tools(Max.)	※3 ※4
	Rear-end Working Driven tool	● 3 tools(Max.)	※3 ※4

※1 Sleeve is optional equipment. Up to 4 rear-end working stationary tool can be mounted depending on the condition.
 ※2 Upper 3 positions are a fixed body unit.
 ※3 The units of lower 1 positions are changeable. (DP).
 ※4 In case that 3-spindle counter face type front drill unit is mounted.

Back 4-Spindle Unit ※5

Stationary tool	● 4 tools
Power-driven tool	● (Max.)

※5 Power-driven units as option.

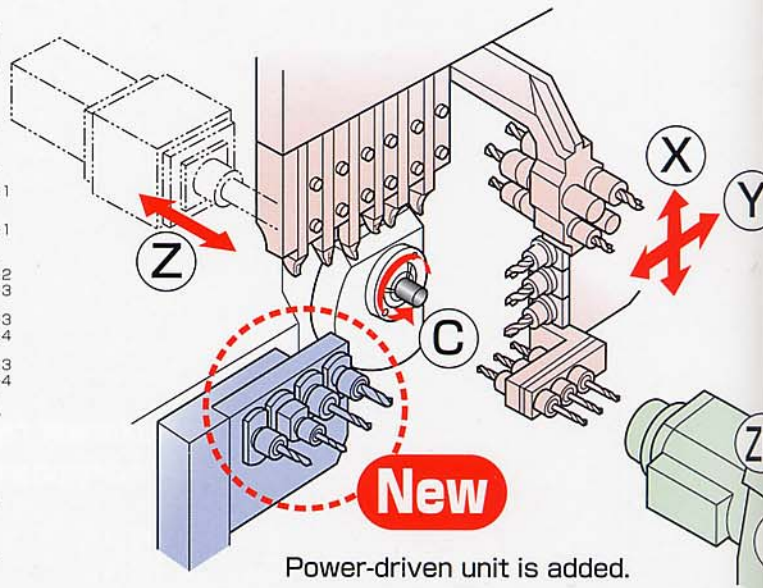

Power-driven unit is added.

Tool post structure separates main and sub spindle machining therefore overlapping opportunities increase and cycle times can be reduced.

The versatile specification extends the machining capability.

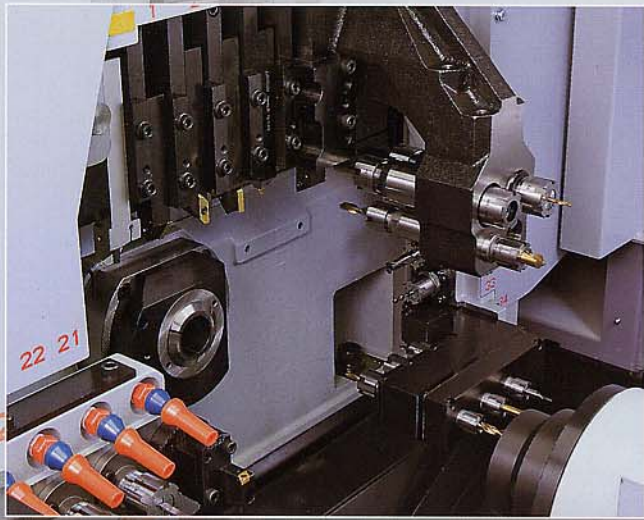

Photo 1 ● Example of additional installation

The drive unit consists of 4 available positions with the upper 3 positions as a fixed unit for drilling and milling tools and the lower 1 position that allows variations to be fitted. Mounting a front drilling unit★ on the lower 1 position makes it possible to increase the available power tools to a maximum of 9 (3 cross working driven tools, 3 front-end working driven tools, 3 rear-end working driven tools) that realizes many machining possibilities including off centre drilling and tapping.

TOOLING PATTERN

1 PATTERN

4 Cross Working Driven Tools

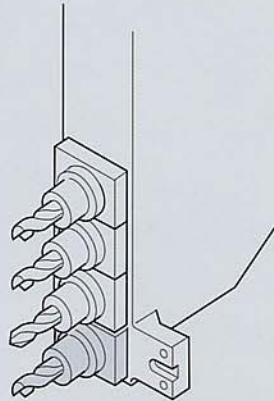

2 PATTERN

3 Cross Working Driven tools
3 Front-end Working Driven tools
3 Rear-end Working Driven tools

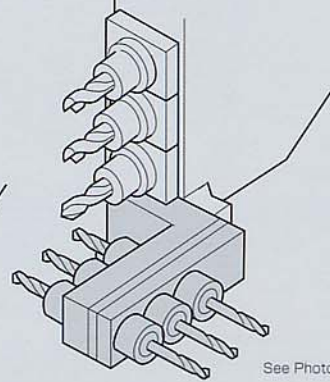

See Photo-1

Variation

variation ①

Cross milling

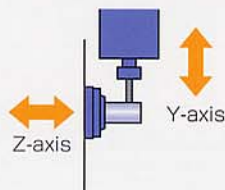
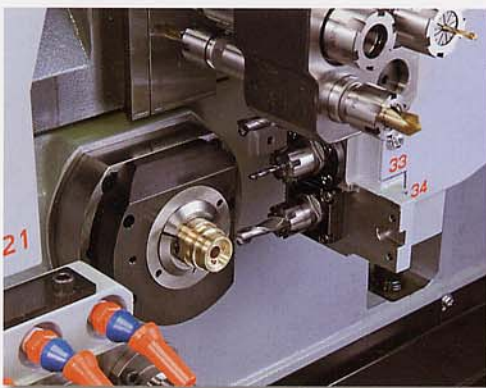

Cross rigid tapping using a cross milling unit is possible.

variation ②

Front off-center drilling

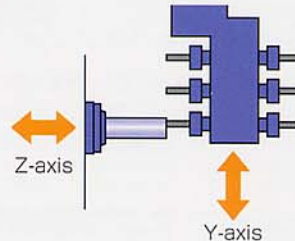
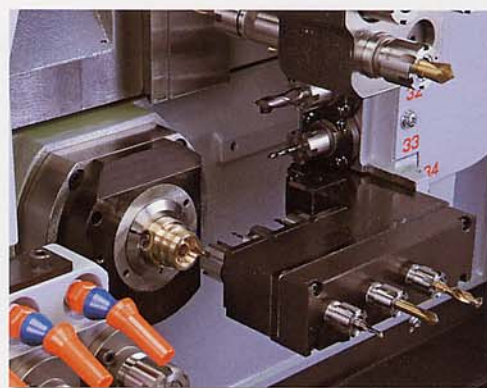

Front rigid tapping is possible.

variation ③

Main/sub spindles



Simultaneous machining on the main and sub spindles is possible.

Secondary machining by command

Photo variation-①②⑤

Up to 9 power-driven tool units can be mounted on the tool holder. Cross milling unit*, front drilling unit* (2-spindle type, 2-spindle counter face drilling unit, 3-spindle type, 3-spindle counter face drilling unit) and the various options are provided to satisfy the demands of complex machining.

Indexing function

C-axis control* is mounted on the main spindle. In addition to the indexing function the 2 axis control of the tool post enables a wide range of secondary machining. The sub spindle has C-axis or 15° indexing as options.

Front off-center drilling

Photo variation-②

Front off-center drilling and off-center tapping (rigid tapping) can be done to completed by mounting a front drilling unit on the tool holder.

Back off-center drilling

Photo variation-⑤

Back off-center drilling and off-center tapping (rigid tapping) can be done by mounting a counter-face drilling unit (2-spindle/3-spindle type) on the tool holder.

Those marked* are option specifications.



Rigid tapping

Photo variation-③

The main spindle, sub spindle and the working driven tool of the tool holder have rigid tapping function as standard specification.

Enhancement of back-face inner / outer diameter machining performance

Back 4-spindle machining

The photograph shows a German made tool, which is available for inner/outer diameter machining on the back side.

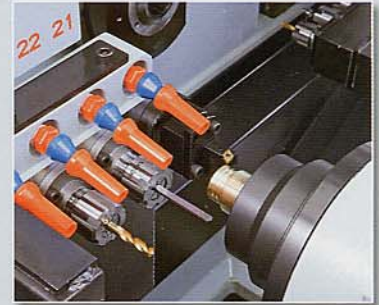

variation ③

Spindle rigid tapping

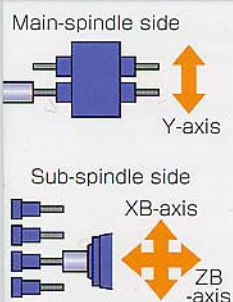

variation ④

Main/sub spindle simultaneous drilling

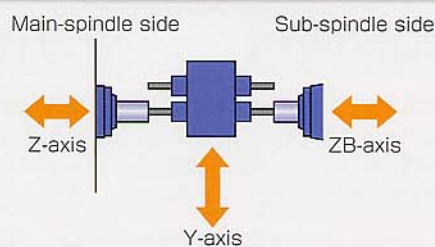
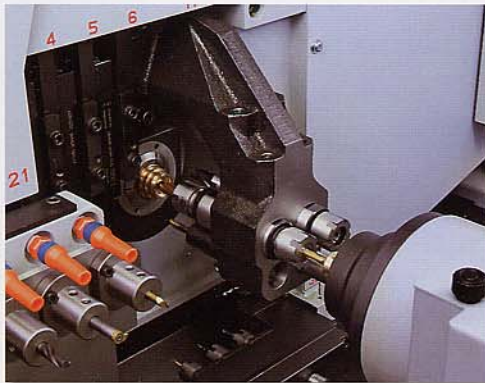

Use of counter-face type tool unit makes this machining possible.

variation ⑤

Back off-center drilling

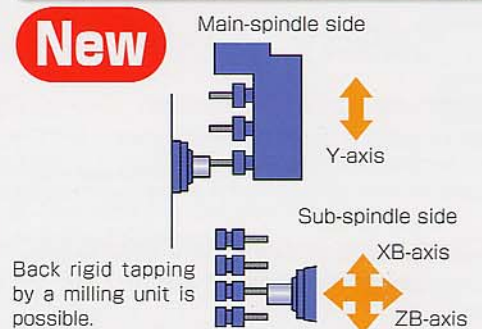
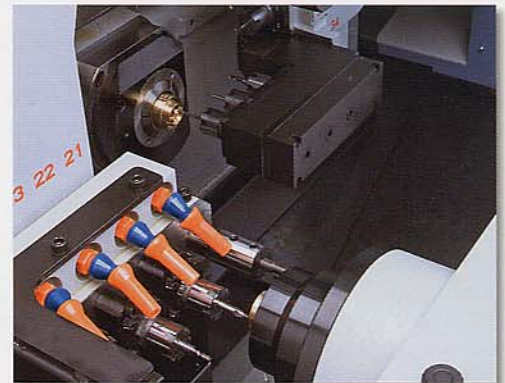



Upgrades of SR-32J NEW Type

- Added Rear-end Working Driven Tool to Back 4-Spindle Unit (Optional)
- Improved rapid feed rate . . . Process time is remarkably shortened thanks to maximum 160% increase of conventional rapid feed rate

**Excellent balance in operability, productivity and economical efficiency.
The new generation design equipped with the environmental-preservation performance.**

High productivity

Advanced CNC unit for faster processing

High speed-program processing by the latest CNC unit.

Servo motor for tool selection

Quick tool selection using the servomotor also greatly contributes to reducing idle time.

New mechanism for collet open/close

Collet opening / closing is possible during main spindle rotation at high speed.

400W coolant pump

The coolant pump reinforced to 400W that increases coolant discharge amount.

Free overlap machining

Machining of HEAD1 and HEAD2 are completely independent. Therefore, overlap machining is possible without being influenced by each other. This also realizes an optimal machining process for reducing cycle time.

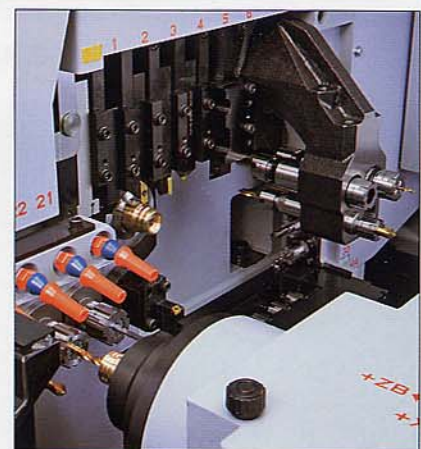

Safety · Comfort · Environment

Absolute position detection

Absolute position detection is standard giving instant zero return when power is turned on.

CE marking specifications

CE marking specifications, machine directive, EMC and low voltage directives are standard in Europe.

Considering global environments and operational environments

Electric power consumption and waste oil level can be reduced thanks to non-hydraulic system.

Economic and Efficient

Basic design improves durability

Oil circulation via a centralized system to all ball screws spindles vastly improves durability.

Standard specification including

Broken cut-off tool detection. Sub spindle air blow and rotary guide bush enhance the appeal of the machine.

Standard Machine Specifications

OP : Option

Item	Specifications
Max. machining diameter	φ32mm(1-1/4in)
Max. headstock stroke	Standard 310mm(12-13/64in)
	With RMGB unit 280mm(11-1/32in)
Tool	Number of tools 6 tools
	Tool shank □16mm×95~155mm, □5/8inch×95~155mm
4-Spindle sleeve holder	Number of tools Front 4 tools : OP Rear 2 tools : OP
	Max. drilling capacity φ 13mm(1/2in)
	Max. tapping capacity M12×P1.75
	Max. die cutting capacity M10×P1.5
Power driven att.	Number of tools 4~9 tools : including OP
	Max. drilling capacity φ 8mm(5/16in)
	Max. tapping capacity M6×P1.0
	Max. milling capacity φ 10mm(25/64in)
Main spindle min. indexing degree	15° (C-axis control : OP)
Main spindle speed	Max.7,000min ⁻¹
Main spindle motor	5.5kw(continuous)/7.5kw(30min)
Rapid feed rate	24m/min (X, Y, Z, ZB, XB)
Power-driven att. spindle speed	Max.5,000min ⁻¹
Power-driven att. drive motor	1.0kw
Coolant tank capacity	174 ℓ
Dimension (W×D×H)	2,711×1,275×1,705mm
Weight	3,100kg
Power consumption	6.0KVA
A-weighted sound pressure : note-1	Max. 71dB (A)

Backworking Attachment Specifications

OP : Option

Item	Specifications	
Max. chucking diameter	φ32mm(1-1/4in)	
Max. length for front ejection	125mm(4-59/64in)	
Max. parts projection length	45mm(1-49/64in)	
4-Spindle unit for backworking	Number of tools 4 tools : OP	
	Max. Stationary tool	φ 13mm(1/2in)
		Power-driven tool φ 6mm(15/64in)
	Max. Stationary tool	M10×P1.5
Power-driven tool M 5×P0.8		
Sub spindle min. indexing angle	15° : OP/C-axis control : OP	
Sub spindle speed	Max.7,000min ⁻¹	
Sub spindle motor	2.2kw(continuous)/3.7kw(15min)	

Note)

The above machining capacities apply to SUS303 material. The machining capacities may differ from listed values depending on the machining conditions, such as the material to be machined or the tools to be used.

★The specifications written in blue characters are reinforced from SR-32J New Types

note-1 : ● Measures in conforming to EN standard.

● A-weighted sound pressure is a general assessment standard characteristic that corrected the sound level to human acoustic sense.

note-2 : ● In order to use the rotary tool, the driven system for power driven attachment B is needed.

※Design features, specifications and technical execution are subject to change without prior notice.

※This product is an export control item subject to the foreign exchange and foreign trade laws. Thus, before exporting this product, or taking it overseas, contact your STAR MICRONICS dealer.

Standard Accessories and Functions

1. Pneumatic unit
2. Coolant level detector (lower limit)
3. Automatic centralized lubrication unit
4. Door interlock unit
5. 6-station tool holder
6. 4-spindle sleeve holder
7. 4-spindle cross drilling unit
8. Main spindle clamp unit
9. Parts conveyor
10. Back 4-spindle unit
11. Main spindle 15° indexing unit
12. Rotary guide bush drive unit
13. Sub spindle air purge
14. Sub spindle air blower
15. Main spindle sub chuck sleeve
16. Guide bush air purge
17. Short circuit breaker
18. Work light
19. Broken cut-off tool detector

Optional Accessories and Functions

1. Rotary magic guide bush unit (RMGB unit)
2. Parts ejector A (Air cylinder type)
3. Parts ejector B (Spring type)
4. Parts separator unit A
5. Main spindle 1° indexing unit
6. Main spindle 15° indexing unit (Sub spindle)
7. Drive unit for power-driven tool type B
8. Coolant flow detector
9. Water removal unit
10. Sub spindle clamp unit
11. Parts stopper
12. Long parts ejector with guide tube
13. Coolant unit 1.5MPa
14. Automatic bar-feeder interface

External Dimensions and Floor Space

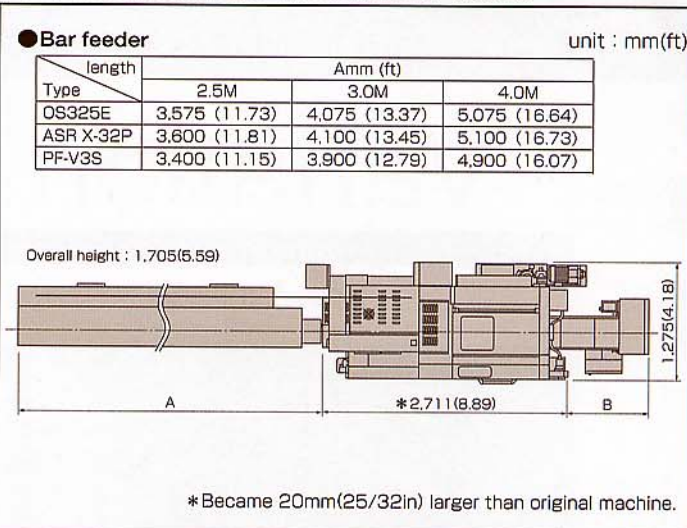

STAR MICRONICS CO., LTD.

Machine Tools Division <http://www.star-m.jp/eng/>

1500-34 Kitanoya, Misawa, Kikugawa, Shizuoka, 439-0023 Japan

America, Europe Sales Sec. TEL.+81-537-36-5594 FAX.+81-537-36-5607

Asia Sales Sec. TEL.+81-537-36-5574 FAX.+81-537-36-5607

Star CNC Machine Tool Corporation
123 Powerhouse Road, Roslyn Heights, NY 11577, U.S.A.
TEL.+1-516-484-0500 FAX.+1-516-484-5820

Star Micronics GB Limited
Chapel Street, Melbourne, Derbyshire DE74 8JF, U.K.
TEL.+44-1332-86-44-55 FAX.+44-1332-86-40-05

Star Micronics GmbH
Untere Reute 44, D-75305 Neuenbürg, Germany
TEL.+49-7082-79200 FAX.+49-7082-792020

Star Micronics AG
Lautstrasse 3, CH-8112 Otelfingen, Switzerland
TEL.+41-43-411-60-60 FAX.+41-43-411-60-66

Star Machine Tool France SAS
55 Avenue du Mont Blanc, F-74950 Scionzier, France
TEL.+33-450-96-05-97 FAX.+33-450-96-91-54

Shanghai Xingang Machinery Co., Ltd.
229 Fute Road(N) Waigaoqiao F. T. Z. Shanghai 200131, P.R.China
TEL.+86-21-5868-2100 FAX.+86-21-5868-2101

Star Micronics (Thailand) Co., Ltd.
49/30 M.4 Soi Kingkaew 30, Kingkaew RD., T.Rachathewa A Bangplee, Samutprakarn 10540, Thailand
TEL.+66(0)2-750-4083 FAX.+66(0)2-750-4085

